

ANALOG INPUTS

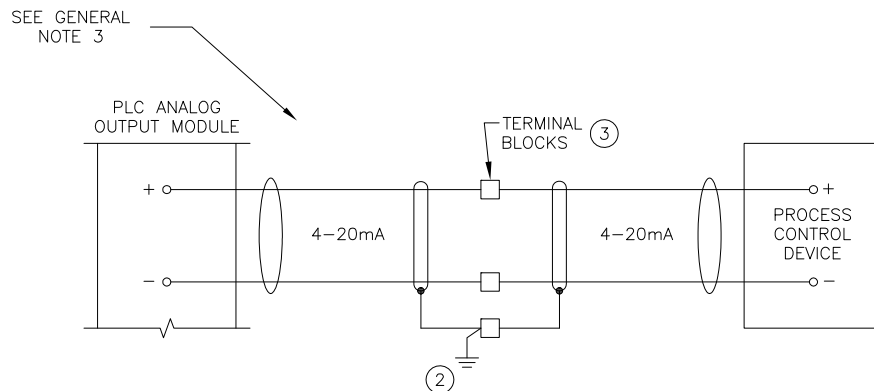

ANALOG OUTPUTS

GENERAL NOTES:

1. CONTROL CABINET WIRING PER SECTION 40 98 00.
2. REFER TO CSO SYSTEM P&ID FOR SPECIFIC PLC I/O POINTS.
3. PROVIDE INTRINSIC SAFETY BARRIERS OR ISOLATORS FOR FIELD INSTRUMENTS OR DEVICES LOCATED IN AREAS CLASSIFIED AS AN EXPLOSION HAZARD. INTRINSIC SAFETY DEVICES SHALL BE INSTALLED PER MANUFACTURER INSTRUCTIONS. INTRINSICALLY SAFE CIRCUITS SHALL BE INSTALLED AND PHYSICALLY SEPARATED PER NEC 500, 504 AND UL REQUIREMENTS.

KEYNOTES:

- ① 24VDC CONTROL POWER SUPPLY IN CABINET/PANEL. REFER TO TYPICAL CONTROL CABINET/PANEL POWER DISTRIBUTION SCHEMATIC ON PREVIOUS SHEET AND COMPONENT SPECIFICATIONS.
- ② ALL ANALOG SHIELD'S TO ISOLATED GROUND BUS.
- ③ CONTROL PANEL TERMINAL BLOCKS.

ANALOG WIRING DIAGRAM

NOTE 1
J04, ZONE B

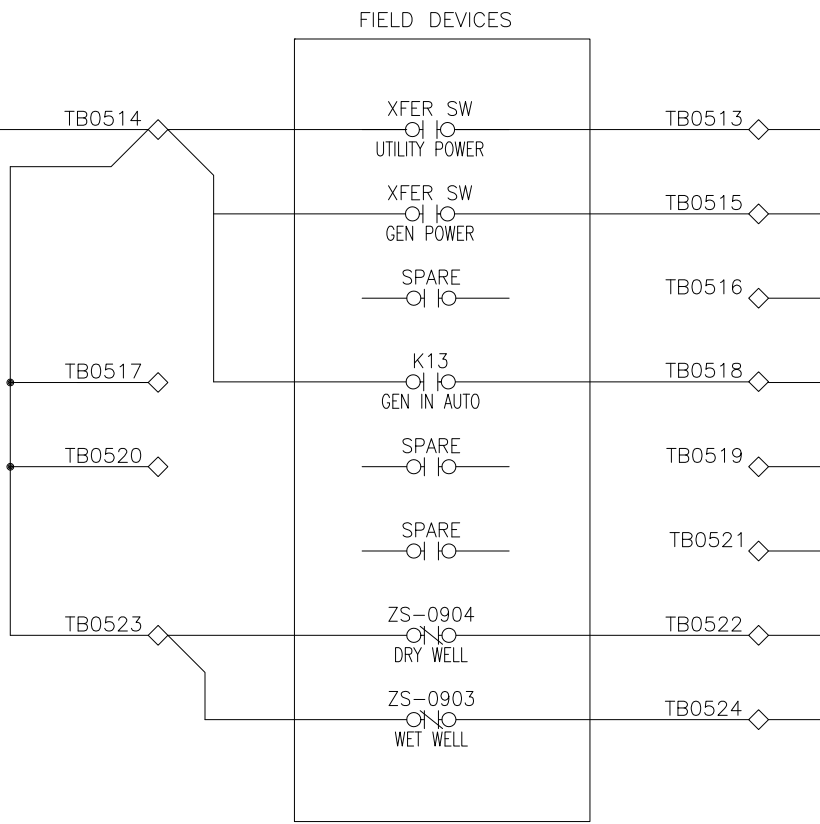

NOTE 1
J05, ZONE B

- 1 TRANSFER SWITCH ON UTILITY POWER DI:00:08
- 2 TRANSFER SWITCH ON GENERATOR POWER DI:00:09
- 3 SPARE DIGIT INPUT DI:00:10
- 4 GENERATOR IN AUTO DI:00:11
- 5 SPARE DIGIT INPUT DI:00:12
- 6 SPARE DIGIT INPUT DI:00:13
- 7 DRYWELL SUPPLY FAN RUN DI:00:14
- 8 WETWELL EXHAUST FAN RUN DI:00:15

(NOTE 1)

NOTE:

1. J01-J12 ARE BREAKOUT BOARD TERMINALS, FOR MORE DETAILS, SEE SNAP-IDC-HDB DATA SHEET.

DISCRETE INPUT WIRING SHEET 2 OF 4

SEE WIRING DETAIL OF IDEC SMART RELAY ON SHEET #8

IDEC SMART RELAY
FLD-H12RCE

NOTE 1
JO7, ZONE C

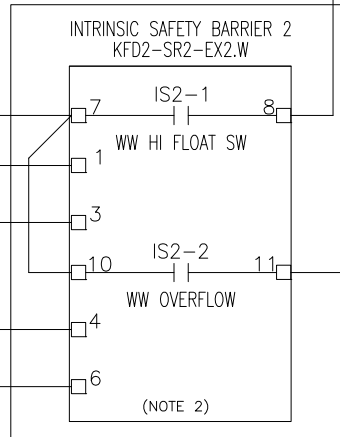
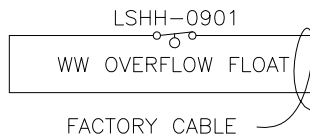
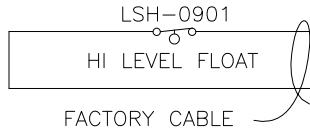

TB0605

NOTE 1
JO8, ZONE C

1 WET WELL HIGH FLOAT
DI:00:16

2 WET WELL OVERFLOW
DI:00:17

NOTE 1
JO7, ZONE C

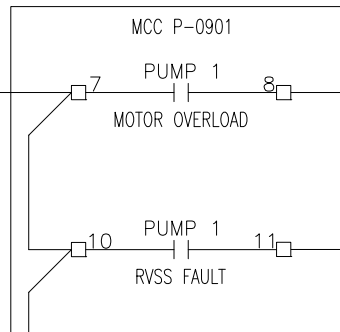

TB0607

3 PUMP 1 MOTOR OL
DI:00:18

TB0608

4 PUMP 1 RVSS FAULT
DI:00:19

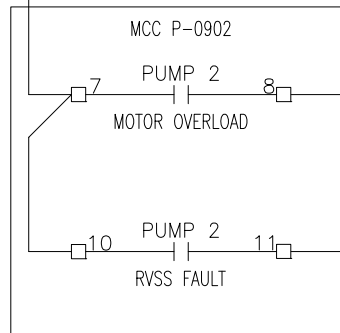

TB0609

5 PUMP 2 MOTOR OL
DI:00:20

TB0610

6 PUMP 2 RVSS FAULT
DI:00:21

(NOTE 1)

(SEE THE INTRINSIC SAFETY BARRIER WIRING DETAIL AS SHOWN ON THIS SHEET)

DISCRETE INPUT WIRING SHEET 3 OF 4

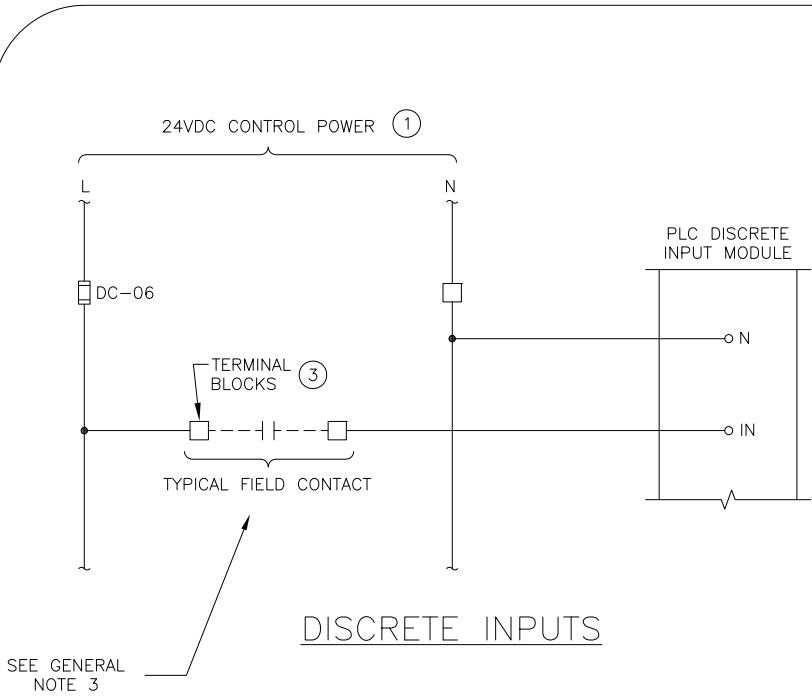

GENERAL NOTES:

1. CONTROL CABINET WIRING PER SECTION 40 98 00.
2. REFER TO CSO SYSTEM P&ID FOR SPECIFIC PLC I/O POINTS.
3. PROVIDE INTRINSIC SAFETY BARRIERS OR ISOLATORS FOR FIELD INSTRUMENTS OR DEVICES LOCATED IN AREAS CLASSIFIED AS AN EXPLOSION HAZARD. INTRINSIC SAFETY DEVICES SHALL BE INSTALLED PER MANUFACTURER INSTRUCTIONS. INTRINSICALLY SAFE CIRCUITS SHALL BE INSTALLED AND PHYSICALLY SEPARATED PER NEC 500, 504 AND UL REQUIREMENTS.

KEYNOTES:

- ① 24VDC CONTROL POWER SUPPLY IN CABINET/PANEL. REFER TO TYPICAL CONTROL CABINET/PANEL POWER DISTRIBUTION SCHEMATIC ON PREVIOUS SHEET AND COMPONENT SPECIFICATIONS.
- ② ALL ANALOG SHIELD'S TO ISOLATED GROUND BUS.
- ③ CONTROL PANEL TERMINAL BLOCKS.

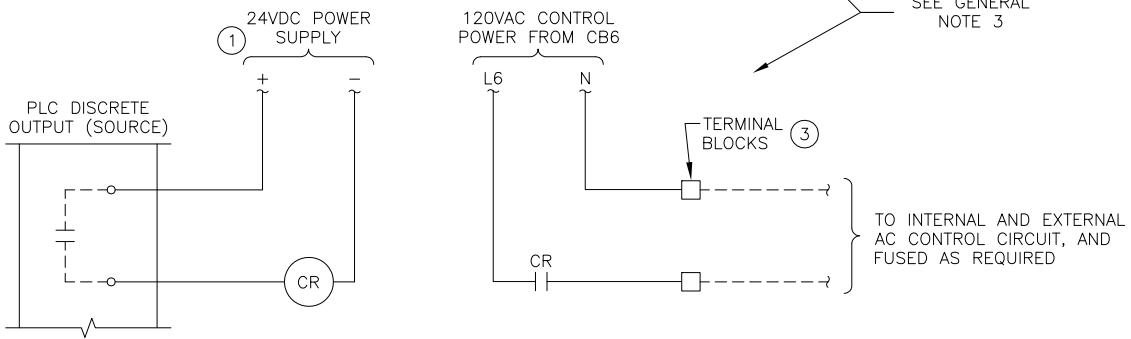
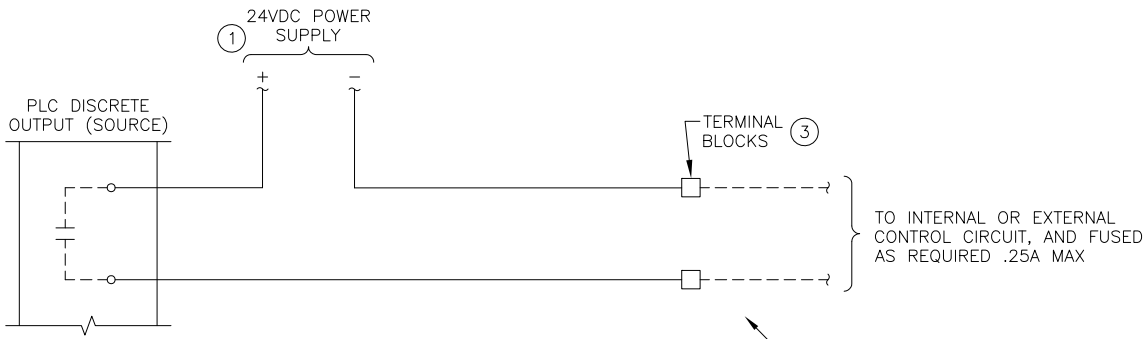

DISCRETE OUTPUTS

DISCRETE WIRING DIAGRAM

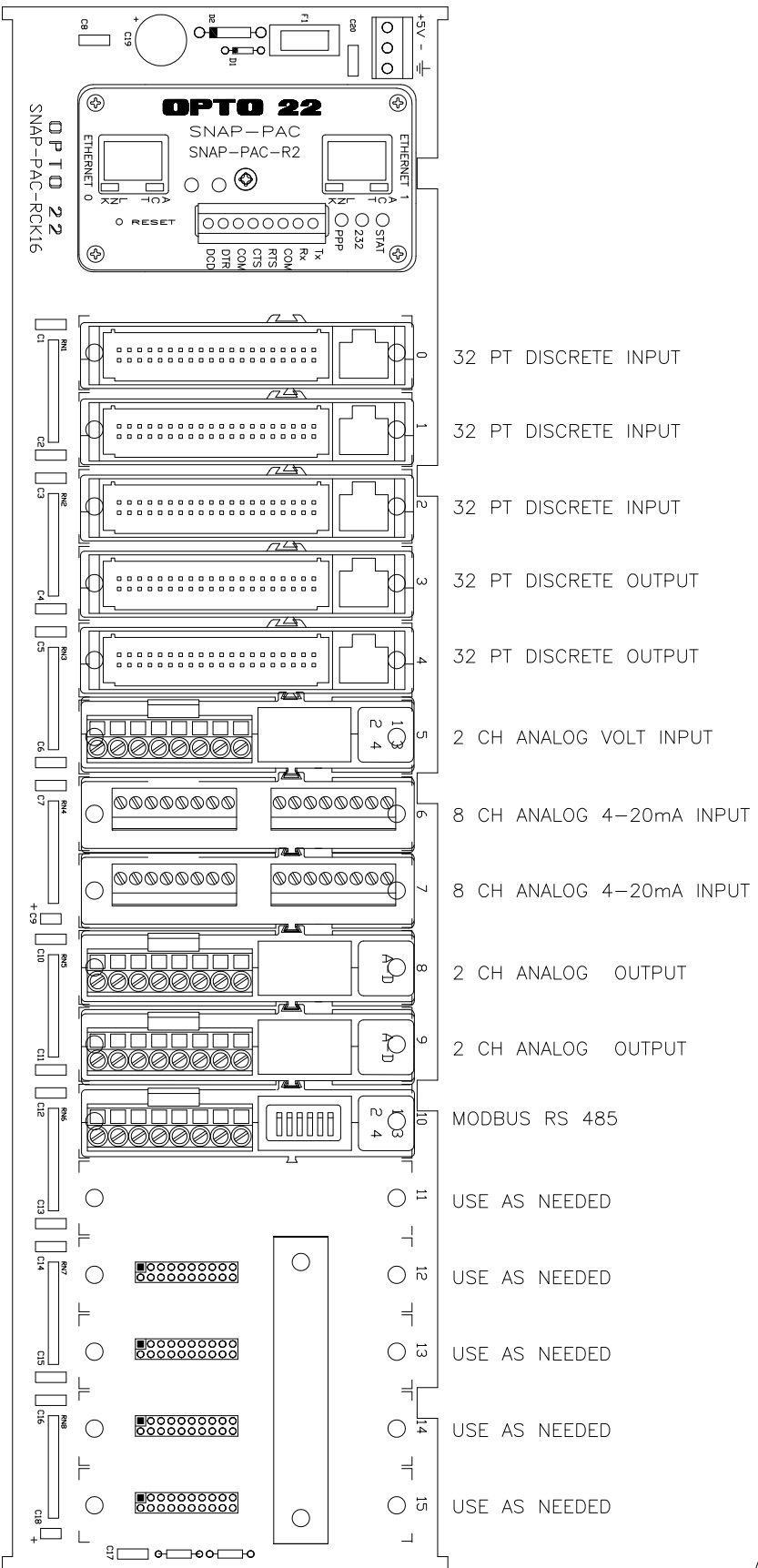

OPTO22 16 SLOT RACK

TYPICAL PAC MODULE
ARRANGEMENT
(LARGE PROJECT)

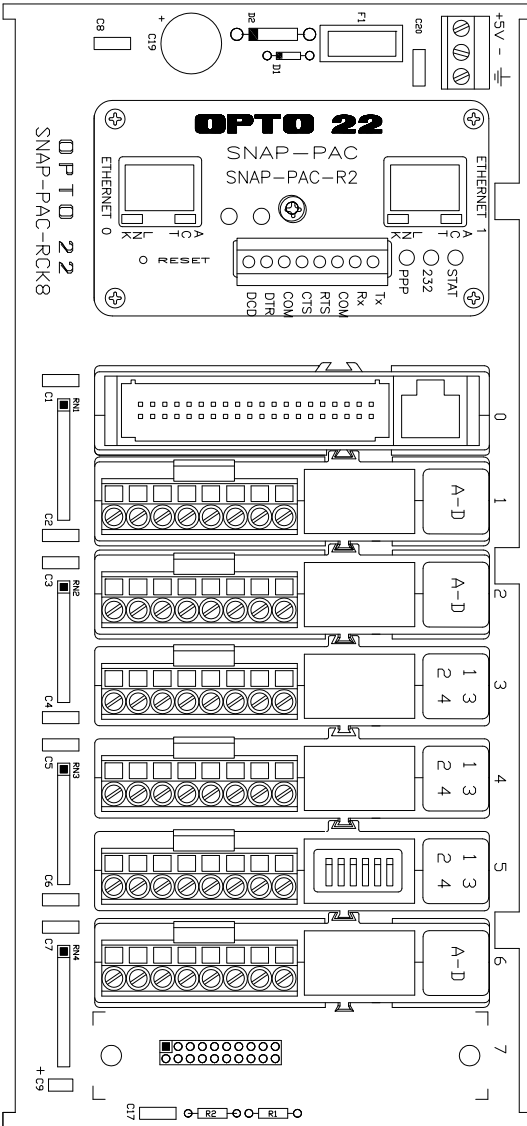
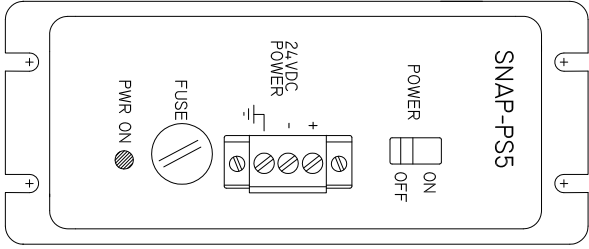

- 0 32 PT DISCRETE INPUT
- 1 ANALOG VOLT INPUT
- 2 ANALOG 4-20mA INPUT
- 3 DISCRETE OUTPUT
- 4 DISCRETE OUTPUT
- 5 MODBUS RS 485
- 6 USE AS NEEDED
- 7 USE AS NEEDED

OPTO22 8 SLOT RACK

TYPICAL PAC MODULE
ARRANGEMENT
(SMALL PROJECT)

